



Effect of isonuclear-alloplasmic cytoplasmic male sterility system on grain yield traits in pearl millet

Mahesh Pujar¹, M. Govindaraj*, S. Gangaprasad¹ and A. Kanatti

International Crops Research Institute for the Semi-Arid Tropics (ICRISAT), Patancheru 502 324, Telangana;
¹University of Agricultural Sciences Shivamogga 577 225, Karnataka

(Received: December 2018; Revised: February 2019; Accepted: March 2019)

Abstract

Pearl millet is a nutri-cereal and is grown predominantly by subsistence farmers in semi-arid regions of India and Africa. Considering its highly cross pollinated nature and availability of cytoplasmic male sterility (CMS), hybrids have become a dominant cultivar type in India. Present study aims to assess the effect of isonuclear alloplasmic A₁, A₄ and A₅ CMS on agronomic performance of pearl millet hybrids. Five isogenic females each having 3 alloplasmic (A₁, A₄ and A₅) cytoplasm were crossed with 6 male-parents to generate 120 hybrids. All these were evaluated in two contrasting seasons (E) in split-split-plot design. The significant cytoplasm *per se* and restorer *per se* indicate the both contribution to most of the traits, however, greater magnitude of contribution arises from restorers significantly (75% grain yield; 95% 1000-grain weight). The significant, hybrids x E shows the mandatory of multi-location testing for yield traits while non-significant of CMS x E interaction reveals the greater stability of CMS. Further, non-significant mean yield differences exhibited in A₁, A₄ and A₅ hybrids (2.84-3.14 t ha⁻¹) indicated no adverse effect of cytoplasm on grain yield and associated traits. Also, diverse genetic backgrounds used in this study displayed significant contributions to grain yield and its component traits. These results imply the prospects for utilization of potential alternative cytoplasm (A₄ and A₅) to widen the cytoplasm base together with development of counterpart restorers to produce future high-yielding hybrids.

Key words: Cytoplasmic male sterility, isogenic, genetic background, hybrid

Introduction

Pearl millet [*Pennisetum glaucum* (L.) R. Br.] is a nutriferous (Rai et al. 2014; Kanatti et al. 2016) and climate resilient cereal grown for food, feed and fodder purpose on about 28 million hectares across the world, primarily in the arid and semi-arid regions of Africa (18

m ha) and Asia (>10 m ha) (Yadav et al. 2012). The productivity of this crop in these environments has varied from low to moderate depending on the choice of cultivars, ability to tolerate drought, erratic precipitations, heat stress and low soil fertility in the regions. Pearl millet reproductive biology plays flexible role for wide range of breeding procedures. Higher outcrossing rate in this crop (>80%) owing to its protogynous flowering nature leads to two broad cultivar types, open pollinated varieties (OPVs) and hybrid cultivars, whereas later one is highly commercially exploitable. With the advent of cytoplasmic male-sterile systems (CMS), hybrid seed production using male sterile lines has become a convenient and economically viable proposition in pearl millet resulting in to hybrids as dominant cultivar types in India. Cytoplasmic-nuclear male sterility, commonly known as CMS in pearl millet refers to failure to produce or release functional pollen and is maternally inherited trait. CMS is controlled by the interaction of sterility inducing factor(s) in cytoplasm with homozygous recessive alleles of nuclear gene (*ms*). Burton (1965) identified the first male sterile cytoplasm source A₁ from Tift 23A. Till today, all the hybrids which are available for commercial use are based on single cytoplasm (A₁ of Tift 23A) posing the possible risk associated with the narrow cytoplasm base causing cytoplasm homogeneity. So far, only A₁ CMS has been utilized largely by NARS as well as multiple seed companies and other CMS types have not been exploited for commercial hybrids. Greater expansion of a single source of CMS in hybrid seed production may likely to have the inevitable consequence of conferring "cytoplasmic uniformity" in the hybrids at

*Corresponding author's e-mail: m.govindaraj@cgjar.org

farmer's fields, consequently narrowing down the cultivar base. Southern corn leaf blight (*Helminthosporium maydis*) in maize associated with Texas (T) cytoplasm (Tatum 1971) which caused epidemics during 1970s in USA was one such past example for risk associated with the cytoplasmic homogeneity. Recent occurrence of leaf blast disease and downy mildew races are critical challenges to hybrid breeding program in pearl millet. Therefore, it is important to use alternate diverse CMS sources in hybrid seed production. These alternate CMS systems on the other hand should not pose any adverse effect on grain yield and other yield related traits or they should not reduce the hybrid performance in order to substitute for A_1 . Cytoplasmic male sterility effect studies have been well documented in sorghum (Lenz and Atkins 1981) and in rice (Young and Virmani 1990). Some efforts have been made in pearl millet (Yadav et al. 1992) to understand the effect of CMS on disease incidence, whereas studies on yield related traits are either very few or they were conducted using single cytoplasm source or on single genetic background. Hence it requires more convincing and elaborated study in terms of different CMS among different nuclear genetic backgrounds and with diverse pollinators. Two different CMS sources such as, A_4 (Hanna 1989) and A_5 (Rai 1995) in pearl millet have shown promising results owing to their stability and availability of their suitable fertility restorers.

Hence, pearl millet cytoplasmic diversification research efforts have been progressing at ICRISAT, India. There is very little knowledge available on the effect of different CMS types on the grain yield of pearl millet hybrids. Considering all these points intact and realizing the importance for requirement of genetic and cytoplasmic diversification of hybrid parents in India, the present study was conducted to assess the effect of three alloplasmic CMS sources A_1 , A_4 and A_5 with five different isonuclear backgrounds on grain yield and its related traits in pearl millet.

Material and methods

Genetic materials

Parental lines for this study were composed of six pollinator lines (Restorers or Male parent), three different alloplasmic male sterile cytoplasm (A_1 , A_4 , A_5) and their fertile (B) cytoplasm in five different genetic backgrounds (Table 1). These parental lines were of diverse parentage which differed for grain yield and various agronomic traits such as plant height, tillering, panicle size and 1000-grain weight and were

Table 1. Parents and genetic backgrounds used in this study

S.No.	Genetic background	CMS/restorer
Female		
1	ICMA\B 842	A_1, A_4, A_5
2	ICMA\B 843	A_1, A_4, A_5
3	ICMA\B 94444	A_1, A_4, A_5
4	ICMA\B 95222	A_1, A_4, A_5
5	ICMA\B 11999	A_1, A_4, A_5
Male		
1	ICMR 1201	A_1, A_4
2	ICMR 100006	A_1, A_4
3	ICMR 100004	A_1, A_4, A_5
4	ICMR 100041	A_1, A_4
5	ICMV 96490	A_1, A_4, A_5
6	Raj 171	A_1, A_4

developed at ICRISAT, Patancheru, India.

Crossing and field trial evaluation

Among five different genetic backgrounds here after referred to as females, each one of these female consisting 3 allo-plasmic (A_1 , A_4 and A_5) male sterile cytoplasm were crossed with each of the 6 pollinators here after referred to as male parents (4 inbreds, 2 populations) during summer season in 2017 to generate total of 120 hybrids (30 hybrids each of A_1F_1 , A_4F_1 , A_5F_1 and BF_1) (Fig. 1). These hybrids were evaluated in Split-Split Plot Design (SSPD) with male parents in main block, different female parents in sub-block and CMS in sub-sub-block. All the entries were replicated thrice, and were evaluated in two contrasting seasons, 2017 rainy and 2018 summer. Plots of each replication were randomized as per SSPD independently using Genstat Statistical package, and the same randomization was followed for both the seasons. Sowing was done by tractor-mounted 4-cone planter (7100 US model), with each entry planted in two rows of 2 m length, and spaced at 75 cm and 60 cm between rows in rainy and summer seasons, respectively. All the recommended agronomic practices were followed for good and healthy crop growth. The observations were recorded on five representative plants in each plot for, plant height (PH), panicle length (PL), panicle girth (PG), thousand grain weight (TGW) while days to 50% flowering (DFF) and grain yield per plot (GY) data were recorded on a plot basis.

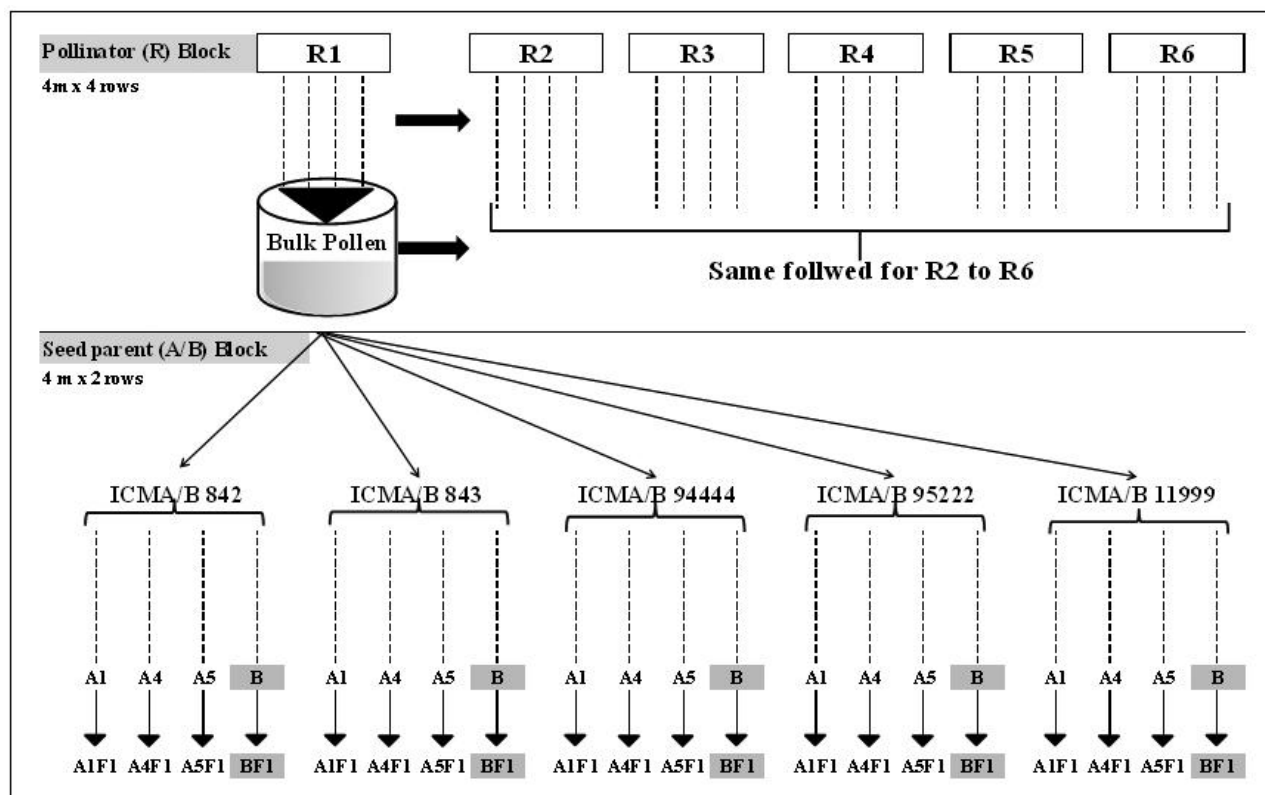

Fig. 1. Schematic representation of crossing plan to produce experimental hybrids

Statistical analysis

All CMS-based hybrids (A×R: A₁F₁, A₄F₁ and A₅F₁) pooled over two seasons were analyzed using *Genstat* version 14, using fixed effect model, which encompassed analysis of variance (ANOVA) in SSPD and pair-wise comparison of treatments. The pooled analysis of variance was done to decide whether the differences among the samples are enough to imply that the corresponding treatment means are different. Combining the thoughts of Montgomery (2013), Gomez and Gomez (1984) and Fisher (1934), the analysis of variance for a split-split plot arrangement was represented in (Table 2). The cytoplasmic effect was calculated as proposed by Sheng and Li (1988).

$$\text{Cytoplasmic effect} = \frac{\overline{AF_1} - \overline{BF_1}}{\overline{BF_1}}$$

where, $\overline{AF_1}$ and $\overline{BF_1}$ are the mean values of A x R and B x R, respectively. The statistical significance of deviation was calculated following 't' test for difference between two means from two independent samples.

Phenotypic correlation coefficient among yield traits were estimated as per Snedecor and Cochran (1967).

Results

Analysis of variance

Pooled analysis of variance for CMS-based hybrids showed highly significant mean squares which indicates that all these hybrids differed in the performance for grain yield and its contributing traits, owing to the presence of ample amount of variability for these traits. The genetic variation attributable to CMS was highly significant for DFF, PH, PL, PG and GY. In contrast to this, TGW showed a non-significant variation (Table 2). The variation attributable to both male parent (R-line) and female (A-line) parent and their interactions were highly significant for all the traits. Environment also showed significant mean square indicating that grain yield and yield related traits were likely to be manifested by environment.

The mean squares for Hybrids x Environment interaction showed significant effect on all the traits studied. CMSxMale parent interactions were

Table 2. Analysis of variance (ANOVA) for grain yield and yield related traits

Source of variation	d.f.	Mean Squares					
		DFF	PH	PL	PG	TGW	GY
Environment (E)	1	1082.2**	164021.5**	322.3**	185.7**	130.5	29.92**
Replication (r)	2	3.5	324.2	0.4	1.8	3.9	0.03
Hybrids (H)	89	16.9**	1167.0**	25.3**	24.8**	92.5**	0.90**
Male (M)	5	123.0**	8887.4**	297.7**	334.5**	127.5**	7.19**
Female (F)	4	156.4**	10883.5**	118.3**	83.9**	15.8**	1.62**
F × M	20	7.4**	378.3**	4.4**	3.9**	2.3**	0.54**
Cytoplasmic Male Sterile (CMS)	2	15.5**	659.0**	15.8**	3.4*	1.2	4.51**
M × CMS	10	1.3*	179.6**	0.5	2.1*	0.8	0.44**
F × CMS	8	0.7	134.6**	2.8**	1.7	1.3**	0.32**
M × F × CMS	40	1.6**	103.9**	3.5**	1.9*	1.4**	0.26**
H × E	89	5.2**	299.1**	2.2**	2.3**	1.5**	0.42**
M × E	5	35.6**	1600.2**	16.1**	6.1	2.1**	0.92**
F × E	4	13.0**	1477.6**	7.7**	1.0**	1.8**	1.40**
CMS × E	2	1.7**	292.3**	1.1	6.5**	1.1*	0.06
M × F × E	20	6.1**	143.4**	1.7*	3.4**	2.9**	0.37**
M × CMS × E	10	0.8**	128.9**	1.1	1.0	0.8**	0.27**
F × CMS × E	8	1.0**	223.1**	0.5	3.1**	1.3**	0.29**
M × GB × CMS × E	40	2.4**	154.5**	0.8	1.4	1.0**	0.37**
Residual	180	0.3	18.9	0.9	1.1	0.3	0.06

* and ** significant at 5% and 1% probability level, respectively

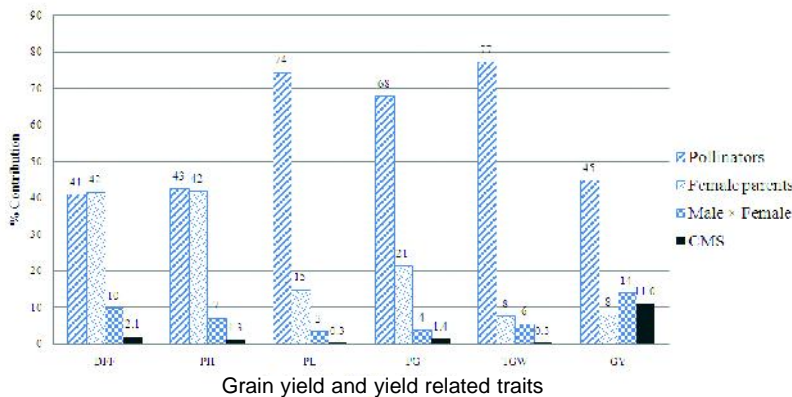

Fig. 2. Percent (%) contribution of each component to the hybrid

significant for DFF, PH, PG and GY. CMS × Female parent interactions were significant for only PH, PL, TGW and GY; whereas interactions between Male × Female and CMS × Male × Female were found significant for all yield related traits (Table 2). The interaction of Male × Environment and Female × Environment has also showed significant effect on all these traits. Interaction of CMS with environment has shown significant effect only for DFF, PH, PG and TGW. The interaction effects of Male × Female

× Environment showed significant effect on grain yield and other traits, whereas Male × CMS × Environment has showed significant effect on most of the yield traits except for PL and PG. Further, except for PL, interaction between Female × CMS × Environment showed significant effect on yield traits. Male × Female × CMS × Environment interaction showed significant effect on all the traits except PL and PG indicating the significant role of environment in modifying the expression of each trait for which the variability was either contributed from male parent, female parent, CMS or any of the interaction between them.

Contribution to yield related traits

Significant effect of female, male and CMS was observed on grain yield

and most of the traits. Hence, it is important to know the percent contribution that each component has towards the individual trait which makes up the total variation in hybrids performance. Major contribution recorded by male parent to yield contributing traits which ranged from 41% (DFF) to 77% (TGW) followed by female parent's contribution with 8% (TGW and GY) to 42% (DFF and PH) (Table 3). Further the interaction between male and female parent contribution ranged from 3% (PL) to 14% (GY) which was in higher proportion than that contributed from CMS (Fig. 2). The significant percent contribution from CMS was in the order of GY (11%) >DFF (2.1%) >PG (1.4) >PH (1.3%) >PL (0.3%) ≥TGW (0.3%). It indicates that, although significant CMS variance shown for most of the traits, CMS alone has very less contribution towards grain yield and its contributing traits in comparison to male or female parent or interaction of male and female parent. Further, as male parent contributed largely, the comparison of male parent contribution against CMS which is the component of interest in the present context indicated that for two important yield traits GY and TGW the contribution from male parent was 75% and 95% respectively, higher than the CMS towards hybrid performance. Whereas for the rest of the traits the male parent contributed more than 95% higher than CMS alone to the hybrid performance.

Comparison among different CMS lines

As confirmed above the percent contribution of CMS against other components was very less towards hybrid performance for each trait and was negligible, the significant effect of CMS as depicted by ANOVA allows us to critically assess the magnitude and its deviation that each CMS produces on pairwise comparison of mean values of respective traits. The pairwise comparison of mean values for all the traits were performed at two levels at their respective LSD. At the first level, the mean values of A₁, A₄ and A₅ (Female × CMS) averaged over all six male parents were compared (Table 3). This showed that the percent significant hybrids for yield and other traits

Table 3. Effect of different cytoplasm on female parents for hybrid yield traits

Female parent x CMS	DFF (days)			PH (cm)			PL (cm)			PG (mm)			TGW (g)			GY (tha ⁻¹)		
	A ₁	A ₄	A ₅	A ₁	A ₄	A ₅	A ₁	A ₄	A ₅	A ₁	A ₄	A ₅	A ₁	A ₄	A ₅	A ₁	A ₄	A ₅
ICMA 842	48	47	48	193.10	186.80	191.20	23.85	24.22	23.47	29.30	29.15	29.55	13.00	13.00	13.00	3.03	2.73	2.98
	b	a	b	b	a	b	ab	b	a	a	a	a	a	a	a	b	a	b
ICMA 843	45	45	45	173.30	172.10	171.10	22.04	22.15	21.48	27.16	27.27	27.17	13.00	13.00	13.00	3.03	2.64	2.95
	a	a	a	a	a	a	b	b	a	a	a	a	a	a	a	b	a	b
ICMA 94444	47	46	47	183.20	184.50	185.40	21.53	21.11	20.52	28.32	28.58	28.64	12.00	13.00	12.00	2.93	2.94	3.21
	b	a	b	a	a	a	b	b	a	a	a	a	a	b	a	a	a	b
ICMA 95222	48	48	48	199.50	193.70	198.30	23.03	22.18	22.46	27.56	26.86	27.68	12.00	12.00	12.00	3.12	2.83	3.26
	a	a	a	b	a	b	b	a	a	b	a	b	a	a	a	b	a	b
ICMA 11999	46	46	46	179.80	173.30	177.90	21.99	21.89	21.62	28.44	28.28	28.47	13.00	13.00	13.00	3.17	3.04	3.31
	a	a	a	b	a	b	a	a	a	a	a	a	a	a	a	ab	a	b
LSD	0.37			3.58			0.43			0.5			0.4			0.16		
S.E	0.13			1.28			0.16			0.18			0.1			0.06		
Difference- Range	0-1			0.9-7			0.1-1.0			0-0.8			0-1			0-0.4		
Average difference	0.4			3.1			0.5			0.3			0.1			0.22		

* Different letter between columns (A₁, A₄, A₅) indicate significant differences for each trait following least significant difference (LSD)

varied in the order of GY(60%) >PH(40%) ≥PL(40%) >DFF(27%) >TGW (13%) and ≥PG(13%) showing average differences of 0.22 tha⁻¹ for GY, 3.1 cm for PH, 0.5 cm for PL, 0.1 g for TGW and 0.3 cm for PG. Whereas all three cytoplasm class flowered on an average at the same time among the significant hybrids indicating that the magnitude and its differences between A₁, A₄ and A₅ for these yield traits were very low and negligible. Second level, the mean values of A₁, A₄ and A₅ (Male × CMS) averaged over all five female parents were compared (Table 4). The percent significant hybrids for yield related traits varied in the order of GY (55%) >DFF (44%) >PL (39%) >PH (28%) >TGW (22%) and >PG (11%) showing average differences of 0.2 tha⁻¹ for GY, 0.4 cm for PL, 3.5 cm for PH, 0.2 g for TGW and 0.3 mm for PG. Whereas in this case also all three cytoplasm types flowered on an average at the same time which also explains that the magnitude of difference between A₁, A₄ and A₅ for any of the yield traits were very less and negligible. Overall mean for individual traits showed that A₁ hybrids flowered in 50 days, while A₄ and A₅ flowered in 46-47 days and no differences with respect to plant height, panicle girth and thousand grain weight were observed. Grain yield on the other hand showed a very close difference among A₁, A₄ and A₅ cytoplasm classes (Table 5).

Effect of CMS on grain yield traits

Using 6 diverse pollinators, 30 hybrids were produced from each alloplasmic A₁, A₄ and A₅ male sterile cytoplasm. Overall mean of hybrids averaged across 30 hybrids among individual cytoplasm class i.e. A₁, A₄ and A₅ when compared with respective overall mean of hybrids developed from B lines showed that there were no significant differences observed for the traits that studied and hence there would not be any cytoplasm effect except for grain

Table 4. Effect of different cytoplasm on restorer (male) parents for hybrid yield traits

Female parent × CMS	DFF (days)			PH (cm)			PL (cm)			PG (mm)			TGW (g)			GY (tha ⁻¹)		
	A ₁	A ₄	A ₅	A ₁	A ₄	A ₅	A ₁	A ₄	A ₅	A ₁	A ₄	A ₅	A ₁	A ₄	A ₅	A ₁	A ₄	A ₅
ICMR 1201	47	46	47	180.1	176.3	178.6	21.51	21.57	21.04	29.60	29.08	29.47	13.00	13.00	13.00	2.99	3.00	3.36
	b	a	b	a	a	a	ab	b	a	a	a	a	a	a	a	a	a	b
ICMR 100006	46	45	46	180.3	174.4	175.4	22.93	22.34	22.15	29.87	29.58	29.38	14.00	14.00	14.00	3.07	2.83	2.93
	b	a	b	b	a	ab	b	a	a	a	a	a	a	a	a	b	a	ab
ICMR 100004	49	49	49	203.3	202.1	201.9	25.96	25.66	25.39	26.13	26.15	26.58	12.00	12.00	12.00	3.48	3.15	3.71
	a	a	a	a	a	a	b	ab	a	a	a	a	a	a	a	c	a	b
ICMR 100041	47	47	47	183.9	176.0	179.8	21.02	20.90	20.45	29.42	29.87	29.82	13.00	14.00	13.00	3.07	2.93	3.24
	a	a	a	b	a	ab	b	ab	a	a	a	a	a	b	a	ab	a	b
ICMV 96490	47	46	47	186.0	188.0	193.3	22.46	22.42	21.81	28.59	28.50	29.27	13.00	13.00	12.00	3.02	2.65	3.01
	b	a	b	a	a	b	b	b	a	a	a	b	b	b	a	b	a	b
Raj 171	47	46	47	181.3	175.7	179.7	21.03	20.98	20.61	25.33	25.00	25.30	11.00	11.00	11.00	2.71	2.46	2.60
	b	a	b	b	a	ab	a	a	a	a	a	a	a	a	a	b	a	ab
LSD		0.43			5.15		0.48			0.66			0.40			0.19		
S.E		0.15			1.76		0.17			0.23			0.10			0.07		
Difference- Range		0-1			0-8		0-0.8			0-0.8			0-1			0-0.6		
Average difference		0.4			3.5		0.4			0.3			0.2			0.2		

*Different letters between columns (A₁, A₄, A₅) indicate significant differences for each trait following least significant difference (LSD)

Table 5. Mean performance of A₁, A₄ and A₅ hybrids for yield traits over two environments

CMS	DFF (days)	PH (cm)	PL (cm)	PG (mm)	TGW (g)	GY (tha ⁻¹)
A ₁ hybrids	50	185.8	22.5	28.2	13	3.06
A ₄ hybrids	46	182.1	22.3	28.0	13	2.84
A ₅ hybrids	47	184.8	23.0	28.3	13	3.14
Mean	47	184.2	22.2	28.2	13	3.01

yield where only A₅ cytoplasm showed significant cytoplasm effect (Table 6). Further, for each trait, the comparison was done with individual cross among each cms class against its respective BF₁ hybrid, which showed that the hybrids in each cms class also did not differ significantly for traits studied including grain yield. For instance, in grain yield, of the 30 hybrids in A₁, A₄ and A₅ cms class only 7 hybrids of A₁, 2 hybrids of A₄ and 9 hybrids of A₅ showed differences in significant proportion. Similarly, 2 hybrids of A₄ and 1 hybrid of A₅ for DFF, 2 hybrids each of A₁, A₄ and 1 hybrid of A₅ for PL, 1 hybrid each in A₁, A₄ and A₅ for PG and 1 hybrid each in A₁, A₄ for TGW showed differences in significant proportion against the respective BF₁ hybrids. For plant height, none of the hybrids in A₁, A₄ and A₅ cms class showed significant difference and also for DFF and TGW none of the hybrids from A₁ cms class showed significant differences against respective BF₁ hybrids, suggesting that largely DFF, PH, PL, PG and TGW would not be altered either by different male sterile cytoplasm or normal (fertile) cytoplasm, in other words cytoplasm would not affect these traits except with slight magnitude of differences for grain yield.

The phenotypic correlation assessed for A×R hybrids (90 AF₁) and B×R (BF₁) hybrids showed that,

Table 6. Cytoplasm effect (CMS) on grain yield and yield related traits

Traits	CMS-Effect		
	A ₁ effect	A ₄ effect	A ₅ effect
DFF	-0.68	-1.79	-0.75
PH	-0.03	-2.02	-0.57
PL	0.40	-0.38	-2.17
PG	-0.98	-1.43	-0.47
TGW	-1.70	-0.77	-2.00
GY	10.04	2.09	13.18

*Significant at 5% probability level

GY had a positive and significant association with PG among A×R hybrids, whereas positive but non-significant association among B×R hybrids (Table 7).

Table 7. Phenotypic correlation among yield traits in hybrids over two environments

	DFF	PH	PL	PG	TGW	GY
DFF	1	0.81**	0.55**	-0.18	-0.45*	0.32
PH	0.86**	1	0.61**	-0.18	-0.38*	0.35
PL	0.67**	0.69**	1	-0.13	-0.07	0.34
PG	-0.18	-0.25	-0.20	1	0.72**	0.17
TGW	-0.28	-0.27	-0.18	0.80**	1	0.07
GY	0.16	0.27	0.11	0.40*	0.32	1

Correlation coefficient in below diagonal is B×R hybrids and above diagonal is A×R hybrids; * and **significant at 5% and 1% probability level, respectively

For other traits in both A×R and B×R hybrids, GY showed positive but non-significant association. TGW showed positive and significant association with PG among both A×R and B×R hybrids, whereas negative and significant association with DFF and PH among A×R, whereas negative but non-significant association for same traits were observed among B×R hybrids, respectively. Flowering being another important trait, showed significant positive association with plant height and panicle length among both A×R and B×R hybrids.

Discussion

Increased efficiency of cms-based hybrid seed production is most promising strategy for enhancing pearl millet productivity. CMS system in pearl millet has been extensively used for more than 50 years to breed male-sterile lines (A-lines) of >160 grain hybrids. Today grain hybrids are grown on more than 4-5 million ha (60%) of pearl millet area in India. All these hybrids have been developed on diverse A-lines almost having single CMS source, i.e. A₁ CMS system. While working with CMS, there is a concern about the effects of male-sterility-inducing cytoplasm on the agronomic traits that are intended to improve in the hybrids. The present study, therefore, reveals the magnitude and direction of CMS effect on grain yield and yield related traits in pearl millet. The significant effect of both male and female parent indicates that both were diverse and significantly differ with respect to yield and yield related traits. Further, percent contribution towards yield and each yield related traits showed that male parent found

to be the largest contributor, followed by female parent. The interaction between male and female parents also contributed to the hybrid performance considerably, which was higher than the contribution of CMS component. All these suggested that the total variation of hybrid performance for most of the traits were accounted by Male parents and Female parents, and then extended to CMS. The similar significant effect of Male and Female and Female \times Male components over grain yield traits were reported by Yadav (1994 and 1996) in pearl millet, by Tao et al. (2011) for TGW in rice, Ramesh et al. (2006) for GY and PH in Sorghum, and Reddy et al. (2009) for DFF, GY and PH in sorghum.

The significance of CMS effect on grain yield and yield related traits, with relatively lower contribution indicates that, there would not be any adverse effect on grain yield and contributing traits or overall hybrid performance, whether we use A_1 or A_4 or A_5 male sterile cytoplasm. It is noteworthy that CMS did not show significant effect on TGW, and no negative correlation between GY and TGW among B \times R and A \times R hybrids could be articulated to narrow range among CMS (averaged 13 g). Some of the earlier studies with significant CMS effect were reported by Yadav (1994) for DFF, PH and GY in pearl millet and Ramesh et al. (2006) in sorghum. Non-significant effect for TGW was also reported by Bozinovic et al. (2015) in maize, These results were further justified by the pair wise comparison of mean values of A_1 , A_4 and A_5 male sterile cytoplasm averaged over all 6 male parents and 5 different female parents. These results showed that the magnitude of difference between pair wise comparison of different cytoplasm for any of the trait was very less. Justifying that the CMS would not produce any adverse effect on grain yield and yield related traits indicating that A_4 and A_5 cytoplasm can be used as potential alternatives to the traditionally used A_1 cytoplasm. Further the overall mean of A_1 , A_4 and A_5 cytoplasm alone across 6 male and 5 female parents for individual trait indicated that A_1 , A_4 and A_5 flower almost at the same time exhibiting similar panicle length, panicle girth and plant height with A_1 and A_5 being slightly taller (3 cm) than A_4 . Whereas for grain yield, A_5 showed non-significant but slightly higher yield in magnitude (3%) than A_1 but significantly higher yield (10%) than A_4 (Table 6). In addition to that, GY is largely determined by the combining ability of parents, heterosis relative to high-parent. The cytoplasmic effects on specific combining ability and heterosis can be restrained/influenced by cytoplasmic-

nuclear interactions. This study fails to indicate that the cytoplasmic effects on combining ability for these traits. Therefore, merits further study in that direction.

Attentions need to be given on the fact that seed or restorer parents interactions with CMS have shown significant effect towards specific yield related traits further three-way interaction Male \times Female \times CMS showed significant effect on all yield related traits. These interactions form the basis that we can use certain type of cytoplasm to derive benefit out of its interaction with specific nuclear genetic background of either male or female parent in order to improve the trait of interest. The CMS line and the counterpart maintainer line possess the same nuclear genome and only differ with respect to cytoplasm sterility. Therefore, the performance of different CMS \times Male hybrid is expected to be equivalent to that of hybrids generated by using respective maintainer line with the same male pollinator (B \times R). Any differences in the performance of these may largely be attributed by the sterile cytoplasm. In the present study a very few hybrids showed significant effect on yield related traits which was evident from the results, among which only grain yield showed relatively higher proportion of significant hybrids in the order of A_5 (30%) $>$ A_1 (23%) $>$ A_4 (7%) compared to other traits. But it is important to know that the narrow differences between mean values of these significant hybrids for grain yield indicating grain yield would not be reduced drastically whether we use normal cytoplasm or sterile cytoplasm. Generally, use of male sterile cytoplasm in hybrid seed production would give possible increase in grain yield in magnitude if not in a significant proportion. Significant cytoplasmic effects were also reported by Waza et al. (2015) for DFF, Sun et al. (2006) for PH. The comparison with the CMS-based hybrid and CMF-based hybrids primarily indicated that the reason for the low yield is likely to be associated with CMS system. However, reasoning CMS effect on yield heterosis is critical and depends on the line per se (A-line/R-line) and its combining ability with counterpart parents, this may cause favorable or unfavorable hybrid combinations. Therefore, a systematic molecular studies on CMS system and cytoplasm effect on grain yield is needed.

In summary, diversification of CMS base forms an important aspect in hybrid breeding program for development of heterotic hybrids in pearl millet and provides possible solution to avoid the risk associated with the cytoplasm homogeneity. With respect to stable CMS and few complete restorers that are available for

A₄ and A₅ cytoplasm, they promise to be alternatives to the commercially exploited A₁ cytoplasm. Present study revealed that the use of A₄ and A₅ cytoplasm would not have adverse effect on grain yield and related traits. Further the mean grain yield of A₅ over female and male lines showed slightly higher yield in magnitude compared to A₁ which would probably give an additional advantage of using alternate CMS. Thus, A₄ and A₅ cytoplasm showed similar hybrid performance over A₁ and hence A₄/A₅ can be used in the hybrid breeding program with increased grain yield by developing potential restorers with high combining ability as did for A₁ so far.

Authors' contribution

Conceptualization of research (MG); Designing of the experiments (MG, SG, MP); Contribution of experimental materials (MG); Execution of field/lab experiments and data collection (MP); Analysis of data and interpretation (MP, AK, MG); Preparation of the manuscript (MP, AK, MG, SG).

Declaration

The authors declare no conflict of interest

Acknowledgement

This research was supported by funding from HarvestPlus Challenge Program of the CGIAR. It was carried as part of the CRP on Agriculture for Nutrition.

References

- Bozinovic S., Prodnovic S., Vancetovic J., Nolic A., Ristic D., Kostadinovic M. and Dragana I. 2015. Individual and combined (Plus-hybrid) effect of cytoplasmic male sterility and xenia on maize grain yield. *Chil. J. Agr. Res.*, **75**(2): April-June 2015.
- Burton G. W. 1965. Pearl millet Tift 23A released. *Crops Soils*, **1**: 19.
- Fisher R. A. 1934. *Statistical methods for research workers*. Landon: University of Landon.
- Gomez K. A. and Gomez A. 1984. *Statistical procedures for agriculture research*. 2nd ed. New York: John Wiley & Sons.
- Hanna W. W. 1989. Characteristics and stability of a new cytoplasmic nuclear male-sterile source in pearl millet. *Crop Sci.*, **29**: 1457-1459.
- Kanatti A., Rai K. N., Radhika K., Govindaraj M. and Rao A. S. 2016. Genetic architecture of open-pollinated varieties of pearl millet for grain iron and zinc densities. *Indian J. Genet.*, **76**: 299-303.
- Lenz M. C. and Atkins R. E. 1981. Comparison of agronomic and morphological characters in sorghum having different cytoplasm. *Crop Sci.*, **21**: 946-1950.
- Montgomery D. C. 2013. *Design and analysis of experiments*. 8th ed. New York: Wiley & Sons.
- Ramesh S. P., Reddy B. V. S., Reddy S. P. and Ramaiah B. 2006. Influence of cytoplasmic-nuclear male Sterility on agronomic performance of sorghum hybrids. *ISMN*, **47**: 21-25.
- Rai K. N. 1995. A new cytoplasmic-nuclear male sterility system in pearl millet. *Plant Breed.*, **114**: 445-447.
- Rai K. N., Patil H. T., Yadav O. P., Govindaraj M., Khairwal I. S., Cherian B., Rajpurohit B. S., Rao A. S., Shivade H. and Kulkarni M. P. 2014. Variety Dhanashakti. *Indian J. Genet.*, **74**: 405-406.
- Reddy B. V. S., Ramesh S. P., Reddy S. and Kumar A. A. 2009. Male-sterility inducing cytoplasmic effects on combining ability in sorghum [*Sorghum bicolor* (L.) Moench] *Indian J. Genet.*, **69**(3): 199-204.
- Sheng X. and Li Z. 1988. Genetic effects of cytoplasm in hybrid rice. In: *Hybrid Rice*, IRRRI, and Manila, Philippines. Pp. 258-259.
- Snedecor G. W. and Cochran W. G. 1967. *Statistical Methods*. Oxford and IBH Publishing Co., New Delhi, 172-195.
- Sun Y., Gu Y. J., Zhang H. G., Tian S., Tang S. Z. and Gu M. H. 2006. Genetic effects of 3 different male sterile cytoplasm in rice. *J. Yangzhou Univ.*, **27**(2): 1-4.
- Tao D., Hu F., Yang J., Yang G., Yang Y., Xu P., Li J., Ye C. and Dai L. 2011. Cytoplasm and cytoplasm-nucleus interactions affect agronomic traits in japonica rice. *Euphytica*, **135**(1): 129-134.
- Tatum L. A. 1971. The southern corn leaf blight epidemic. *Science*, **171**: 1113-1116.
- Waza S. A. 2015. Identification of restorers and effect of WA cytoplasm on the physico-chemical grain quality characteristics in hybrid rice (*O. sativa* L.) Ph.D Thesis.
- Yadav O. P. 1994. Effect of cytoplasmic source on the combining ability of agronomic traits in pearl millet. *Plant Breed.*, **113**: 242-245.
- Yadav O. P. 1996. Downy mildew incidence of pearl millet hybrids with different male-sterility inducing cytoplasm. *Theor. Appl. Genet.*, **92**: 278-280.
- Yadav O. P., Khairwal I. S. and Singh S. 1992. Smut severity of pearl millet hybrids with male-sterile and fertile cytoplasm. *Euphytica*, **64**: 139-142.
- Yadav O. P., Rai K. N., Rajpurohit B. S., Hash C. T., Mahala R. S., Gupta S. K., Shetty H. S., Bishnoi H. R., Rathore M. S., Kumar A., Sehgal S. and Raghvani K. L. 2012. Twenty-five years of pearl millet improvement in India. All India Coordinated Pearl Millet Improvement Project, Jodhpur.
- Young J. B. and Virmani S. S. 1990. Effect of cytoplasm on heterosis and combining ability for agronomic traits in rice (*Oryza sativa*). *Euphytica*, **48**: 177-188.